

BALL VALVE (TRUE UNION)

SIZE: 1/2" - 3"

SERIES PVC-340

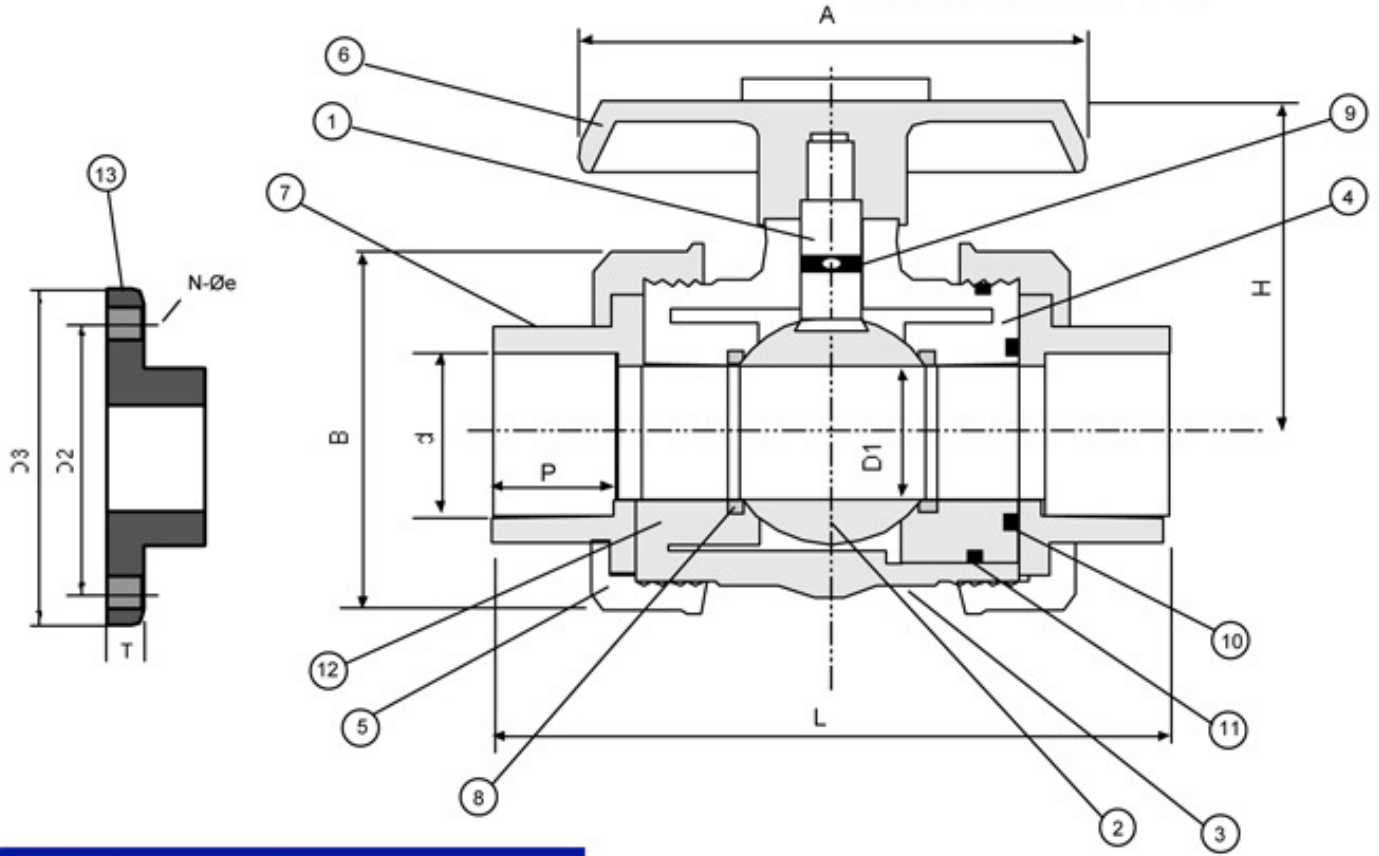

Materials of Construction

Item	Parts	Pcs	Materials
1	Stem	1	PVC,PP,CPVC,PVDF
2	Ball	1	PVC,PP,CPVC,PVDF
3	Body	1	PVC,PP,CPVC,PVDF
4	Seat Carrier	1	PVC,PP,CPVC,PVDF
5	Union Nut	2	PVC,PP,CPVC,PVDF
6	Handle	1	ABS
7	End Connector	2	PVC,PP,CPVC,PVDF

Item	Parts	Pcs	Materials
8	Seat	2	TEFLON®
9	Stem O-Ring	1	EPDM,VITON®
10	Seat Carrier O-Ring	1	EPDM,VITON®
11	Body O-Ring	1	EPDM,VITON®
12	Solid End O-Ring	1	EPDM,VITON®
13	Flange	2	PVC,PP,CPVC,PVDF

VITON® and TEFLON® are trademarks of DuPont Performance Elastomers

Ansi Dimensions

Size Inch	D ₁	D ₂	D ₃	d		e	n	P	L			A	T	H	B	Working Pressure (PSI)
				Socket	Thread				Socket	Thread	Flange					
1/2"	.591	2.375	3.500	0.840	NPT 1/2"	0.625	4	0.875	4.049	4.049	5.640	3.240	.590	2.028	2.114	150
3/4"	.799	2.750	3.875	1.050	NPT 3/4"	0.625	4	1.000	4.843	4.843	6.670	3.976	.590	2.638	2.500	150
1"	1.024	3.125	4.250	1.315	NPT 1"	0.625	4	1.125	5.689	5.689	7.090	4.390	.630	2.697	2.874	150
1 1/4"	1.20	3.500	4.625	1.660	NPT 1 1/4"	0.625	4	1.250	6.520	6.520	8.510	4.340	.630	2.768	3.228	150
1 1/2"	1.50	3.875	5.000	1.900	NPT 1 1/2"	0.625	4	1.375	7.160	7.160	9.280	4.780	.630	3.340	3.850	150
2"	1.89	4.750	6.000	2.375	NPT 2"	0.750	4	1.500	7.950	7.950	10.150	5.880	.787	3.850	4.733	150
2 1/2"	2.64	5.500	7.000	2.889	NPT 2 1/2"	0.750	4	1.750	8.860	8.860	11.540	7.480	.787	5.51	5.91	150
3"	3.15	6.000	7.500	3.516	NPT 3"	0.750	4	1.875	10.830	10.830	14.920	9.050	.866	6.54	7.20	150

Testing performed on PVC/EPDM valves at 73°F water temperature, non-shock.