

## SERIES 425 CARBON STEEL GATE VALVES

**Standards:**

Face to Face Dimensions: ANSI B16.10  
 End Flange Dimensions: ANSI B16.5  
 26" ≥ MSS SP-44  
 Or API 605  
 Basic Design: API 600  
 API 603 (316 Valves)  
 Test Standard: API 598



**MATERIAL LIST**

NO.	Part Name	ASTM Specification (Specs – Grades/Types)				
		A 216	A 352	A 217	A 351	
		WCB	LCC	WC6	C5	CF8M
1	Body	A 216-WCB	A 352-LCC	A 217-WC6	A 217-C5	A 351-CF8M
2	Seat Ring	A 105, LF2, 316, or 304				
	Seat Ring Surface	13CR, HF (CoCr-A), 316, 304, or Monel				
3	Gate	A 216 – WCB	A 352-LCC	A 217-WC6	A 217-C5	A 351-CF8M
	Gate Seating Surface	13CR, HF (CoCr-A), 316, 304, or Monel				
4	Stem	13CR, 316, 304, 17-4PH, or Monel				
5	Gasket	Graphite Jacketed Stainless Steel				
6	Bonnet	A 216 – WCB	A 352-LCC	A 217-WC6	A 217-C5	A 351-CF8M
7	Bonnet Bolt Nut	A 194-2H	A 194-4	A 194-2H	A 194-4	A 194-8
8	Bonnet Bolt	A 193-B7	A 320-L7	A 193-B7	A 193-B16	A 193-B8
9	Bonnet Bushing	13CR, 316, or 304				
10	Packing	Braided Graphite & Die Formed Graphite Ring				
11	Eye Bolt Pins	Carbon Steel				
12	Gland Eye Bolts	A 193-B7	A 320-L7	A 193-B7	A 193-B8	
13	Gland	13CR, 316, or 304				
14	Gland Flange	A 216 – WCB	A 352-LCC	A 217-WC6	A 217-C5	A 351-CF8M
15	Eye Bolt Nut	A 194-2H	A 194-7M	A 194-2H	A 194-8	
16	Grease Nipple	Carbon Steel				
17	Yoke Sleeve	A 439 Gr. D2C				
18	Retaining Nut	Carbon Steel				
19	Handwheel	Malleable Iron				
20	Handwheel Nut	Carbon Steel				
21	Screw	Carbon Steel				
22	Yoke Pad Bolts	A 193-B7				
23	Yoke Pad Bolt Nuts	A 194-2H				
24	Bearing	Carbon Steel				
25	Stud	Carbon Steel				
26	Gear	Carbon Steel				
27	Yoke	A 216 – WCB	A 352-LCC	A 217-WC6	A 217-C5	A 351-CF8M
28	Yoke Pad Bolt	A 193-B7	A 320-L7	A 193-B7	A 193-B16	A 193-B8
29	Yoke Pad Bolt Nuts	A 194-2H	A 194-4	A 194-2H	A 194-4	A 194-8

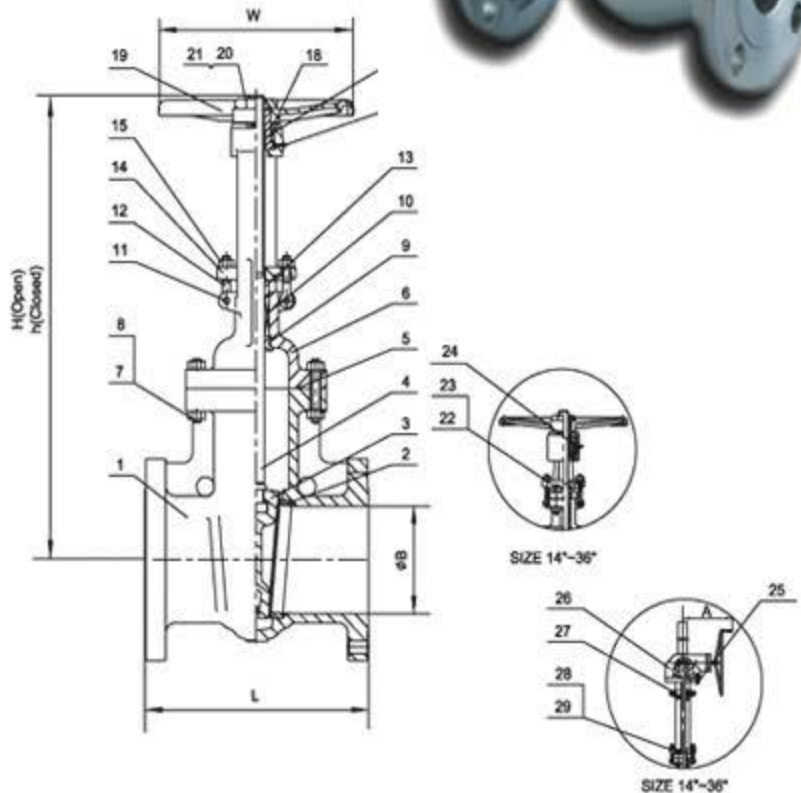

**DIMENSIONS AND WEIGHTS**

Size	NPS	2	2-1/2	3	4	5	6	8	10	12	14	16	18	20	24	26	28	30	32	36
L (RF)	In	7.00	7.50	8.00	9.00	10.00	10.50	11.50	13.00	14.00	15.00	16.00	17.00	18.00	20.00	22.00	24.00	24.00	26.00	28.00
	Mm	178	190	203	229	254	267	292	330	356	381	406	432	457	508	559	610	610	660	711
L (RTJ)	In	7.50	8.00	8.50	9.50	10.50	11.00	12.00	13.50	14.50	15.50	16.50	17.50	18.50	20.50	22.50	24.50	24.50	26.50	28.50
	Mm	191	203	216	241	267	279	305	343	368	394	419	445	470	521	572	622	622	673	724
L (BW)	In	8.50	9.50	11.12	12.00	15.00	15.88	16.50	18.00	19.75	22.50	24.00	26.00	28.00	32.00	34.00	36.00	36.00	38.00	40.00
	Mm	216	241	283	305	381	403	419	457	502	572	610	660	711	813	864	914	914	965	1016
A	In										14.17	14.17	14.17	16.18	16.18	23.62	23.62	23.62	23.62	23.62
	Mm										360	360	360	411	411	600	600	600	600	600
B	In	2	3	3	4	5	6	8	10	12	13	15	17	19	23	25	27	29	31	34.5
	Mm	51	64	76	102	127	152	203	254	305	337	387	483	489	591	643	692	743	781	876
h	In	13	14	16	18	21	24	29	35	41	46	54	60	67	79	94	102	111	113	118
	Mm	328	361	412	469	534	599	746	882	1052	1173	1362	1530	1698	2018	2387	2590	2819	2870	2997
H	In	15.28	17.48	19.57	23.03	26.65	30.12	37.95	45.47	53.62	60.43	71.30	79.09	87.80	103.98	121.50	130.98	141.97	145.98	154.49
	Mm	388	444	497	585	677	765	964	1155	1362	1535	1811	2009	2230	2641	3086	3327	3606	3708	3924
W	In	8	10	10	10	12	12	14	16	18	20	22	25	25	28	34	34	34	35	35
	Mm	200	250	250	250	300	300	350	400	450	500	560	640	640	720	860	860	860	900	900
WT	KG	18	28	34	52	71	88	144	197	298	430	548	744	1117	1466	1699	2010	2380	3100	3950
	LB	40	62	75	115	157	194	317	434	657	948	1208	1640	2463	3232	3746	4431	5247	6834	8708