

# STAINLESS STEEL KNIFE GATE VALVES

Fabricated stainless steel lined body ideally suited for dense or abrasive media both wet and dry

Stainless steel gate, seat and raised face

Body cavity, seat configuration and beveled gate designed to provide shut-off capability in thick media such as pulp stock, slurries or with solid media such as pellets or powders.

Smooth flow non-clogging FULL PORT design.

Valve seat face is protected by gate in both open and closed positions.

Full range of operators available including air cylinder, bevel gear or electric actuators.

Precision machined stainless steel gate for superior seating capability.

Designed and tested to MSS-SP-81 dimensions and specifications.

Can be manufactured in special materials such as ALLOY 20, HASTELLOY, TITANIUM and MONEL for severe services.

Flanges matches ANSI B16.5-150 lbs. standard with all tapped holes, serrated gasket faces.

Hard face seats, V-Port or resilient seats available to suite the specific service.

Custom designed sizes, pressures and configurations available.

## Used in these industries:

Pulp & Paper	Mining
Power	Chemical
Industrial	Petroleum



**FABRICATED  
SLIDE GATE  
VALVE**

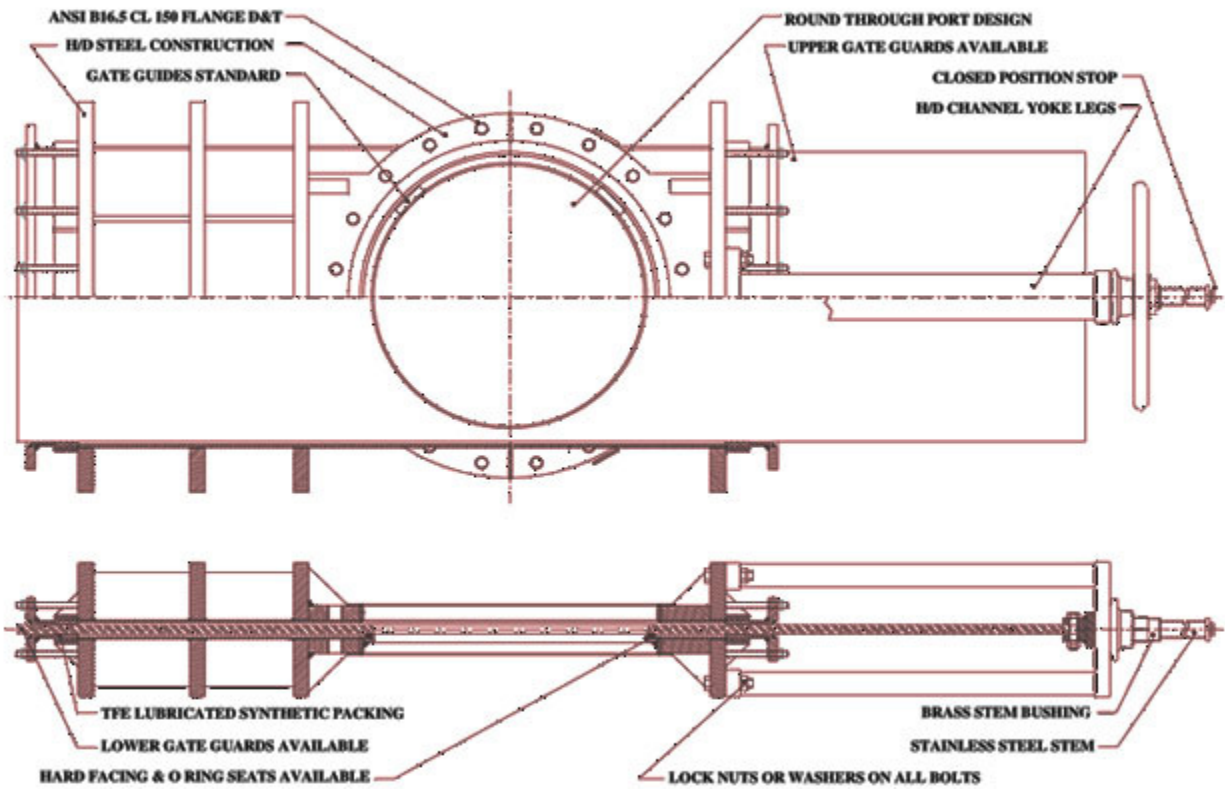

VALVE SHOWN IN OPEN POSITION

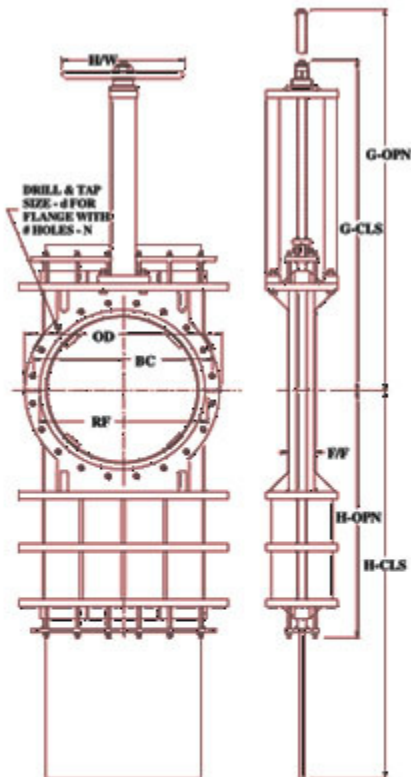

**DIMENSIONS AND WEIGHTS:**

	VALVE SIZE										
	3"	4"	6"	8"	10"	12"	14"	16"	18"	20"	24"
<b>F/F</b>	2"	2"	2-1/4"	2-3/4"	2-3/4"	3"	3"	3-1/2"	3-1/2"	4-1/2"	4-1/2"
<b>BC</b>	6"	7-1/2"	9-1/2"	11-3/4"	14-1/4"	17"	18-3/4"	21-1/4"	22-3/4"	25"	29-1/2"
<b>RF</b>	5"	6-3/16"	8-1/2"	10-5/8"	12-3/4"	15"	16-1/4"	18-1/2"	21"	23"	27-1/4"
<b>OD</b>	7-1/2"	9"	11"	13-1/2"	16"	19"	21"	23-1/2"	25"	27-1/2"	32"
<b>N/d</b>	4 5/8"-11	8 5/8"-11	8 3/4"-10	8 3/4"-10	12 28"-9	12 28"-9	12 1"-8	16 1"-8	16 1-1/8"-7	20 1-1/8"-7	20 1-1/4"-7
<b>G-CLS</b>	18-3/4"	20-1/2"	24-3/8"	28-1/2"	32-1/8"	36"	38-3/4"	42-1/2"	45-3/4"	47-1/2"	55-3/4"
<b>G-OPN</b>	22"	24"	31"	36"	43-5/8"	48-3/4"	51-1/2"	58"	63-3/4"	66-1/2"	79-3/8"
<b>H-CLS</b>	11-3/4"	14-1/2"	19-3/8"	24-1/2"	30-1/8"	36"	38-3/4"	44-1/2"	49-3/4"	54-1/4"	65-1/4"
<b>H-OPN</b>	9"	10"	13-1/4"	16-1/2"	19-5/8"	23-3/4"	24-3/4"	28-1/2"	31-3/4"	34"	41-1/2"
<b>H/W</b>	8"	8"	12"	12"	16"	16"	20"	20"	20"	20"	20"
<b>Weight</b>	75	92	122	170	245	340	445	565	640	915	1145

**MATERIALS:**

	MATERIAL CODE				
	304	304	316	316	317
<b>BODY, SEAT and RF</b>	304	304	316	316	317
<b>GATE</b>	304	304	316	316	317
<b>PACKING GLAND</b>	STEEL	304	STEEL	316	317
<b>FLANGES, EXT. TRIM</b>	STEEL	304	STEEL	304	304
<b>YOKE</b>	STEEL	304	STEEL	304	304
<b>STEM &amp; CLEVIS</b>	304	304	304	304	304
<b>STEM BUSHING</b>	BRASS	BRASS	BRASS	BRASS	BRASS
<b>BOLTING</b>	PLATED	304	PLATED	304	304
<b>PACKING</b>	TFE	TFE	TFE	TFE	TFE