

FLANGED STANDARD BALL VALVE SERIES 295

**CLASS 150
 BLOW OUT PROOF STEM
 LOCKING DEVICE
 ANTI-STATIC DEVICE**

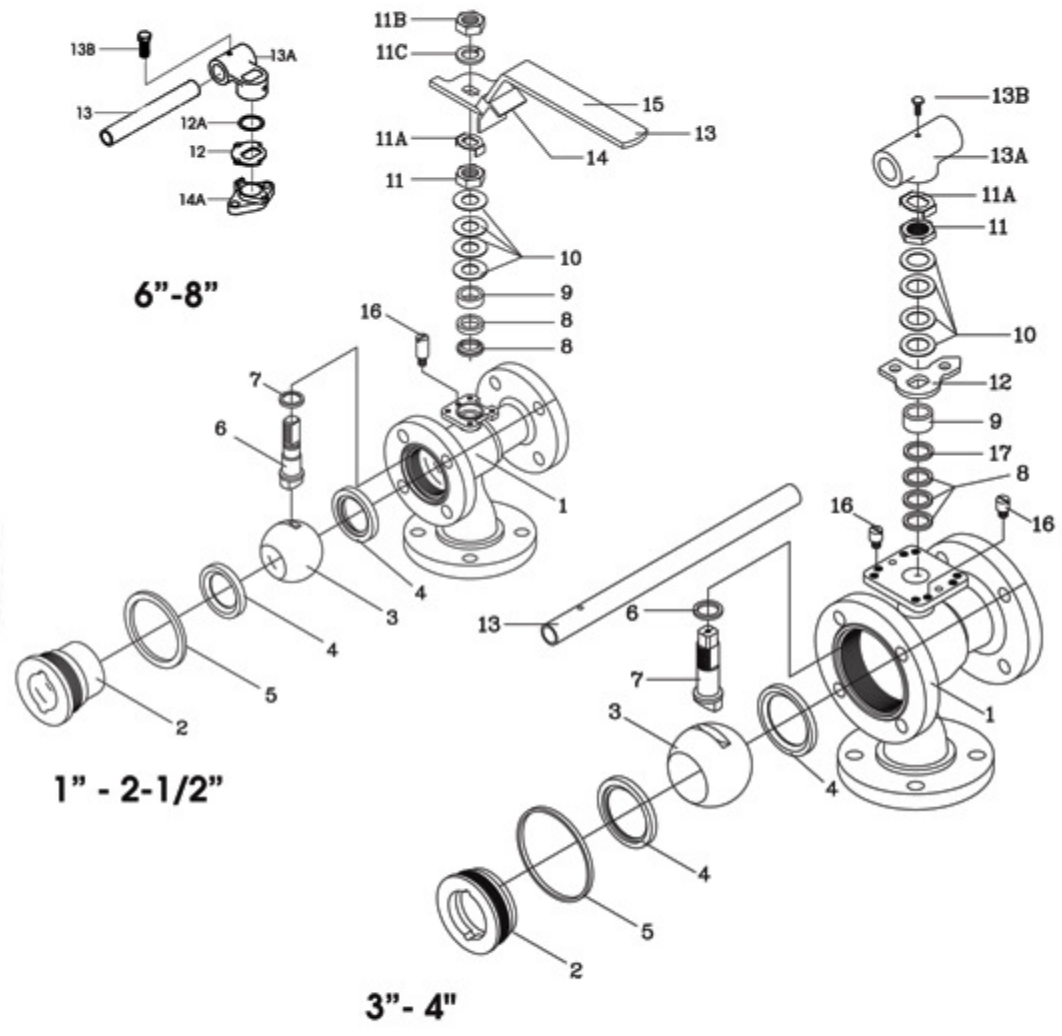

PART NO.	PART	QTY.	MATERIAL
1	Body	1	316 Stainless Steel ASTM A351 CF8M Carbon Steel ASTM A216 WCB Alloy 20 ASTM A351 CN7M
2	End Connector	1	316 Stainless Steel ASTM A351 CF8M Carbon Steel ASTM A216 WCB Alloy 20 ASTM A351 CN7M
3	Ball	1	316 Stainless Steel Alloy 20
4	Seat	2	TFM(Super TFE) TFE Reinforced TFE
5	Body Seal	1	TFE
6	Stem	1	316 Stainless Steel / Alloy 20 / 17-4PH (Option)
7	Thrust Bearing	2	Reinforced TFE
8	Stem Packing	3/4	Reinforced TFE
9	Gland Packing	1	304 Stainless Steel
10	Belleville Washer (1\"-4")	2/4	304 Stainless Steel
11	Packing Nut (1\"-4")	1	304 Stainless Steel
11A	Lock Tab (1-1/2\"-4")	1	Stainless Steel

PART NO.	PART	QTY.	MATERIAL
11B	Handle Nut (1-1/2\"-2")	1	304 Stainless Steel
11C	Lock Washer (1-1/2\"-2")	1	304 Stainless Steel
12	Stopper	1	304 Stainless Steel
12A	Snap Ring	1	Stainless Steel (6\"-8")
13	Handle 3\"-8\" Lockable Handle 3\"-8\" Lockable Handle	1	304 Stainless Steel (1-1/2\"-2\") Galvanized Steel (2-1/2\"-4\") Stainless Steel (3\"-4\") Ductile Iron (6\"-8")
13A	Wrench Block	1	Stainless Steel
13B	Hex Head Bolt	1	304 Stainless Steel
14	Locking Device (1-1/2\"-2")	1	304 Stainless Steel
14A	Gland Flange	1	304 Stainless Steel
15	Sleeve	1	Vinyl
16	Stop Pin (1-1/2\"-2") (2-1/2\"-4")	1 2	304 Stainless Steel 304 Stainless Steel
17	Stem Packing Protector Ring	1	304 Stainless Steel

1" - 2-1/2"

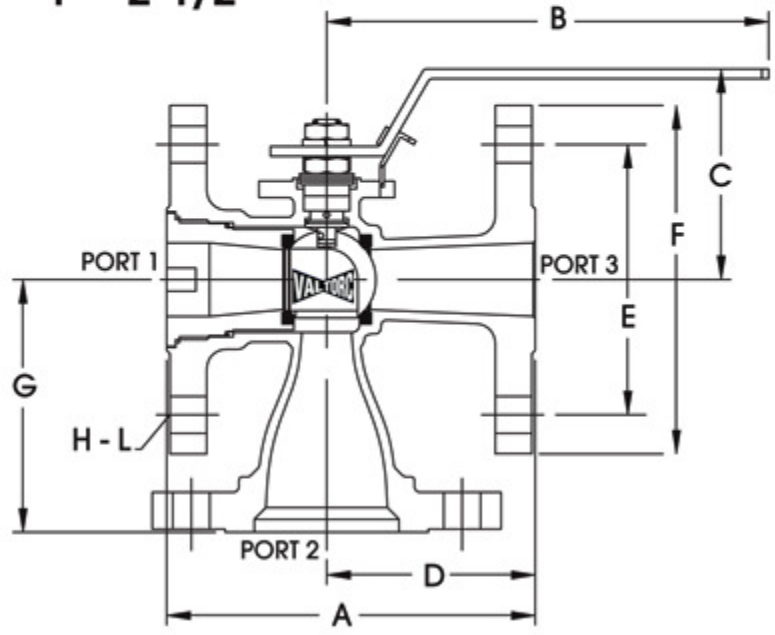

3" - 4"

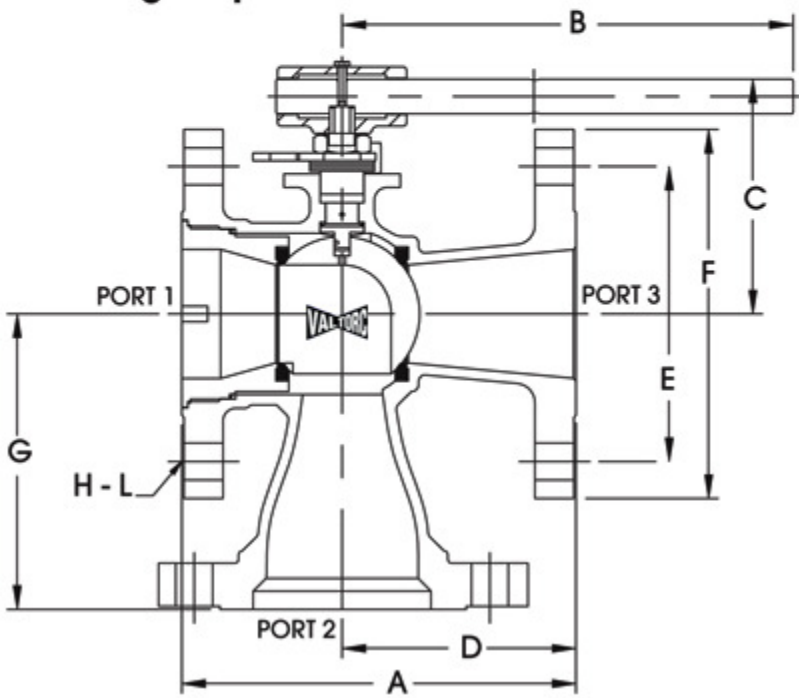

6" - 8"

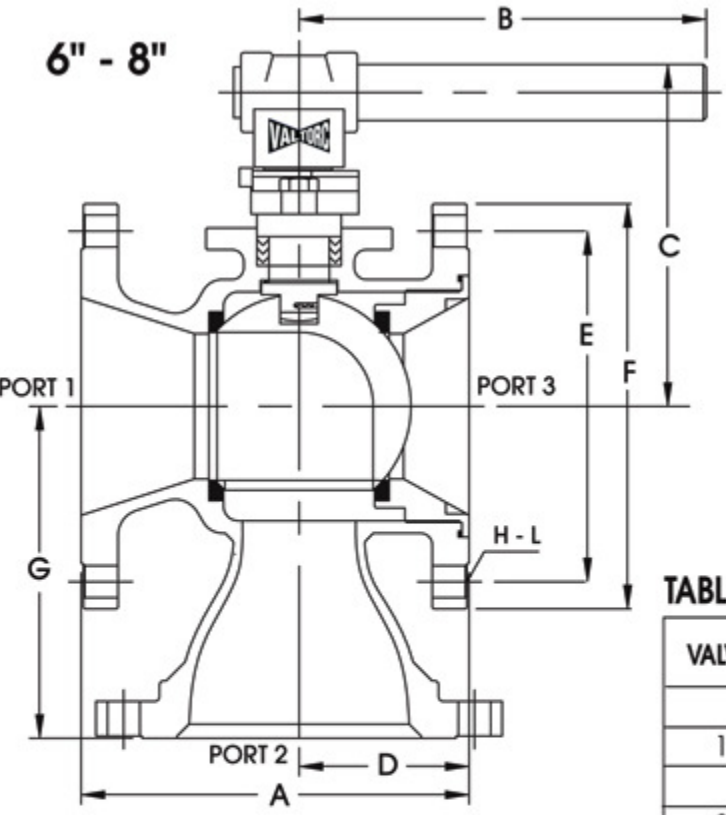

TABLE A

VALVE SIZE	PORT 1	PORT 2	APPROXIMATE WEIGHT (LBS)	CV (US GPM)
1	0.75	0.62	8.5	15
1-1/2	1.25	1.0	13.9	36
2	1.50	1.25	22.4	54
2-1/2	2.00	1.5	40.8	90
3	2.50	2.07	46.8	195
4	3.00	2.47	67.3	360
6	4.00	3.07	146.9	540
8	6.00	4.02	211.3	810

*CV: The volume of water in gal./min. that will pass through a given valve with a pressure drop of 1 PSI.

TABLE B

VALVE SIZE	A	B	C	D	E	F	G	H	L
1	5.00	4.75	3.60	2.50	3.12	4.25	3.13	4	0.63
1-1/2	6.50	6.30	4.00	3.64	3.88	5.00	4.00	4	0.63
2	7.00	8.98	4.50	4.41	4.75	6.00	5.00	4	0.75
2-1/2	7.50	9.00	5.50	3.94	5.50	7.00	5.50	4	0.75
3	8.00	13.74	6.57	4.00	6.00	7.50	6.00	4	0.75
4	9.00	13.74	6.95	4.49	7.50	9.00	7.15	4	0.75
6	10.50	25.60	9.27	4.61	9.50	11.00	9.00	8	0.86
8	11.50	25.60	10.43	5.85	11.75	13.50	11.00	8	0.86

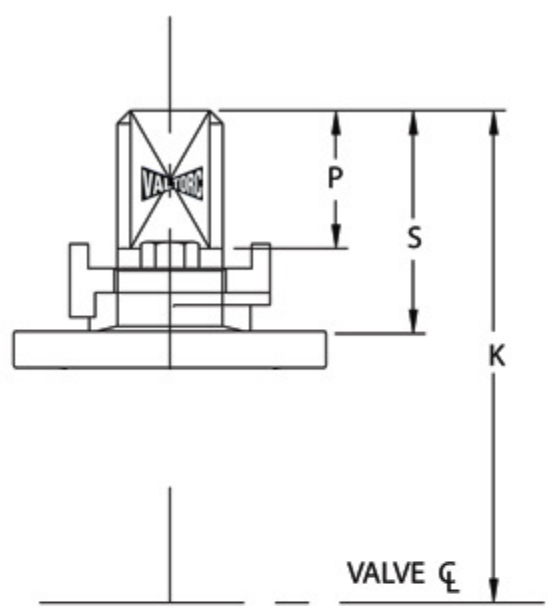
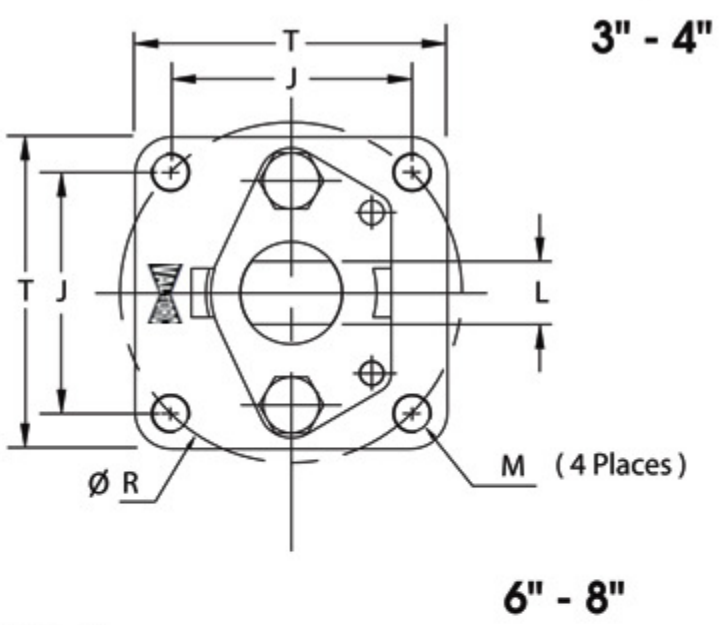
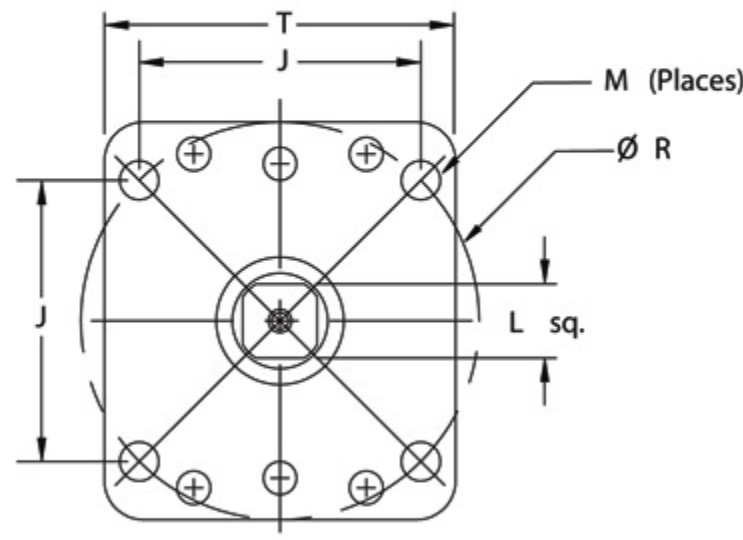
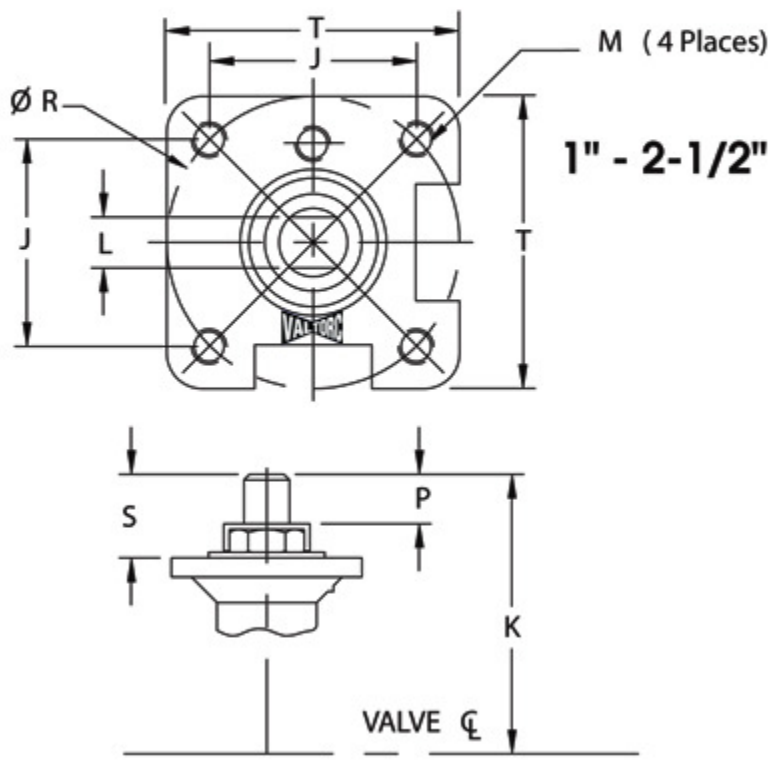
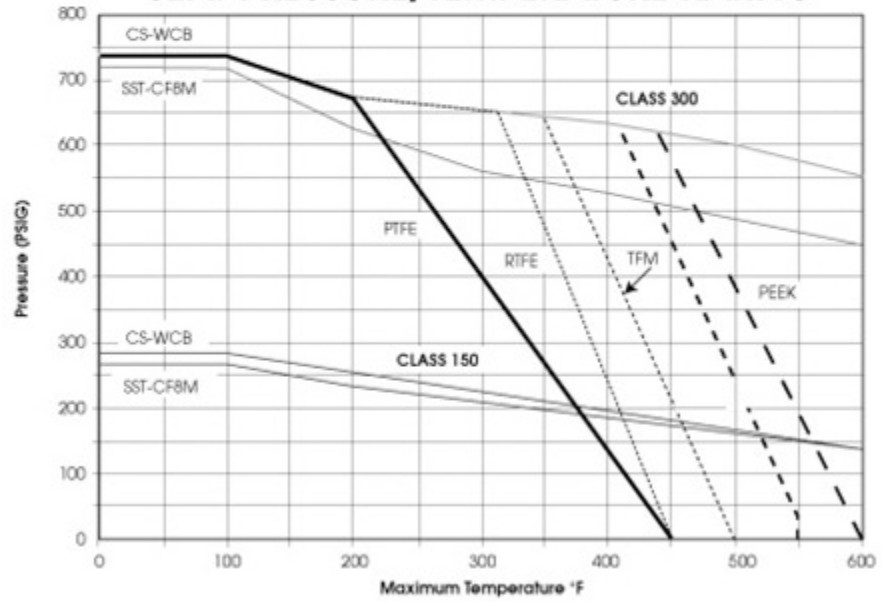

TABLE C

VALVE SIZE	J	K	L	M	P	R	S	T
1	1.39	2.22	0.23	M6 x 1.0	0.30	1.67	0.75	1.97
1-1/2	1.97	2.01	0.35	M8 x 1.25	0.42	2.75	0.83	2.75
2	1.95	2.36	0.35	M8 x 1.25	0.42	2.75	1.14	2.75
2-1/2	1.95	2.63	0.55	M8 x 1.25	0.69	2.75	1.19	2.75
3	2.84	5.71	0.75	M10 x 1.5	0.69	4.02	1.87	3.54
4	2.84	6.15	0.75	M10 x 1.5	0.69	4.02	1.87	3.54
6	2.84	8.22	1.02	5/8-18 UNC	1.69	4.02	3.07	4.02
8	3.48	10.44	1.02	M12 x 1.75	1.65	4.92	3.58	4.92

SEAT PRESSURE/TEMPERATURE RATING



FLOW PATTERN

The Diverter Valve is designed to accept media through the bottom (Port 2) and direct the flow to either of the two outlet ports, Port 1 or Port 3.

