

VALTORC PROFIBUS VALVE POSITION CONTROLLERS



▶ Profibus Valve Position Controllers

The Valtorc VPCs with encapsulated Profibus interface cards adapt your on/off automated valves to an advanced Profibus DP valve network. The Profibus protocol was developed in 1989 by a group of factory automation suppliers.

Profibus-DP is a device level bus network that supports both analog and discrete signals. Profibus-DP has widespread usage for such items as remote I/O systems, motor control centers, and variable speed drives. Profibus-DP communicates at speeds from 9.6 Kbps to 12 Mbps over distances from 100 to 1,000 meters.

▶ Advanced Profibus DP Platform Improves Reliability

The Network Card. A full function encapsulated network card for the network protocol includes the following benefits:

- > Encapsulated electronics and position sensors ensures reliability in corrosive, humid and dirty environments.
- > Hall effect position sensors designed into the card provide optimum stability in areas of high vibration.
- > Two transistor outputs with a combined output of up to 4.8w @ 24VDC are available for your solenoid valves
- > High visibility LEDs are located on-board for local indication of on-board sensors, auxiliary inputs, outputs and network status.
- > Two additional inputs are available for local pressure or temperature switches.

The Physical Platform. Valtorc's platform is available in many configurations:

- > Housings in Aluminum, Hard Anodized Aluminum or SuperTough Zytel® for General Purpose or Hazardous Areas
- > Valtorc's proven Engineered Loc-Ring Cam and Shaft Retention System assures stable output signals in difficult environments over a multi-million cycle life.
- > Optional Mini and Micro plug connectors can be fitted to the conduit entries of the enclosures to speed installation.

The Visual Indicator. Valtorc's High Visibility Valve Position Indication preferred by users worldwide are available in a wide variety of colors and flow patterns.

The Solenoid Valve. Low power solenoid valves optimized for the network card output are available with direct NAMUR actuator mounting or pre-wired to the VPC.

▶ Profibus® DP Technical Information

- > Each Network Supports up to 32 Devices per Segment or 64 With Repeaters
- > Automatic Baud Rate up to 500K bit/sec.
- > Up to 1000 m Maximum Trunk Length Without Repeaters
- > Supports Both Discrete and Analog Signals
- > I/O Modules Allow Connection of Conventional Analog and Discrete Devices
- > Interfaces Available for Many Variable Speed Drives, Motor Control Centers, and Field Devices > Supports 32 Devices per Segment, 62 with Repeaters
- > Simple Integration of New Devices into an Existing Network
- > Supports Mono-Master and Multi-Master Systems

VALTORC PROFIBUS VALVE POSITION CONTROLLERS

Wiring Diagram

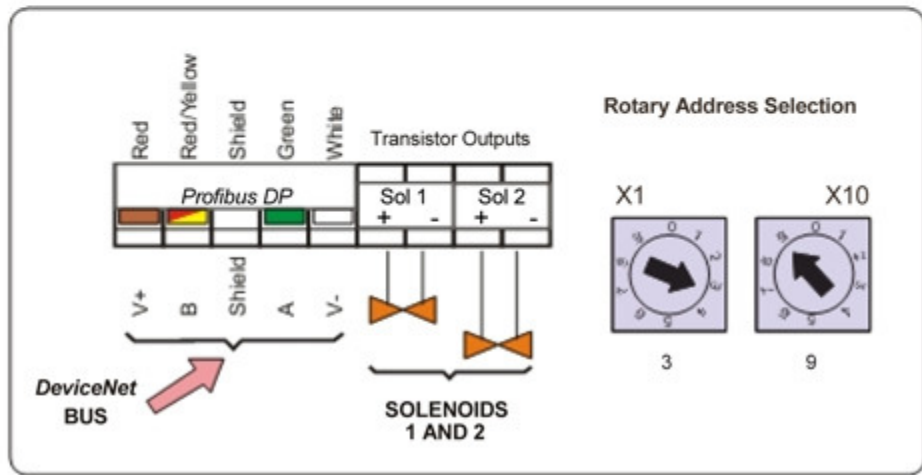

Standard Profibus[®] Network Card Specifications

Power		On-Board Sensor Inputs	
Voltage	24Vdc ±10%	Type	(2) Hall Effect Solid-State Sensors, (1) for Each Valve Position
Current	<40mA	Local Indication	Red LEDs
Communication		Solenoid Output	
Type	Slave	Type	(2) Transistor Programmable to NO or NC
Communication	Polled	Transistor Rating	24VDC / 2 X 200 mA
Word	1 Byte TX, 1 Byte RX	Indicator	(2) Red LEDs
Addressing	0 to 99, by Rotary Switch		
Transmission Rate	up to 500 Kbaud		
Local Indication			
Green (Light)	Active and Allocated		

