

VALTORC

WWW.VALTORC.COM
AJBENTAL@VALTORC.COM
1 (866) VALTORC

SERIES PA-2000

PNEUMATIC ACTUATORS



DOUBLE ACTING & SPRING RETURN

Working Condition

Temperature: from 0° to + 80°C; from - 20°C to +80°C with dry air only. (from -40°C to +150°C in special execution)
 Air supply: Minimum 40 psi; Maximum 130 psi
 Operating media: Compressed filtered air, not necessarily lubricated.
 In case of lubricated air, either non detergent oil or NBR compatible oil must be used.

Double Acting Operation

***CCW**
 Air is supplied to Port A forcing the pistons away from each other (towards ends), rotating the drive pinion counter-clockwise and exhausting air out of Port B

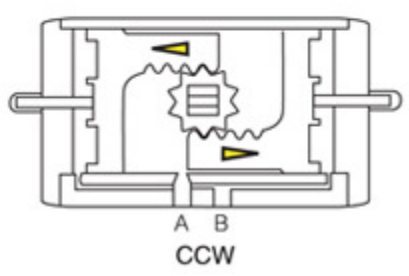

***CW**
 Air is supplied to Port B forcing the pistons toward each other (towards center), rotating the drive pinion clockwise and exhausting air out of Port A

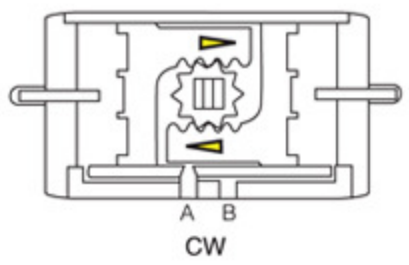

Spring Return Operation

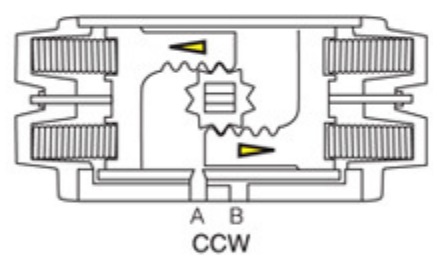

***FAIL CCW**
 Air is supplied to Port A forcing the pistons away from each other (towards ends), rotating the drive pinion counter-clockwise, compressing the springs and exhausting air out of Port B

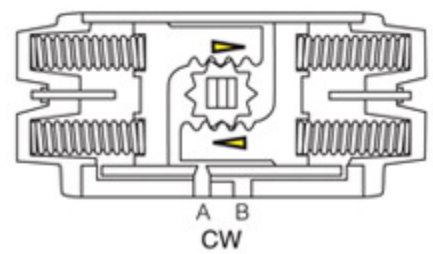

***FAIL CW**
 Air failure (loss of pressure) allows the compressed springs to force the pistons toward each other (towards center), rotating the drive pinion clockwise and exhausting air out of Port A

MATERIALS OF CONSTRUCTION

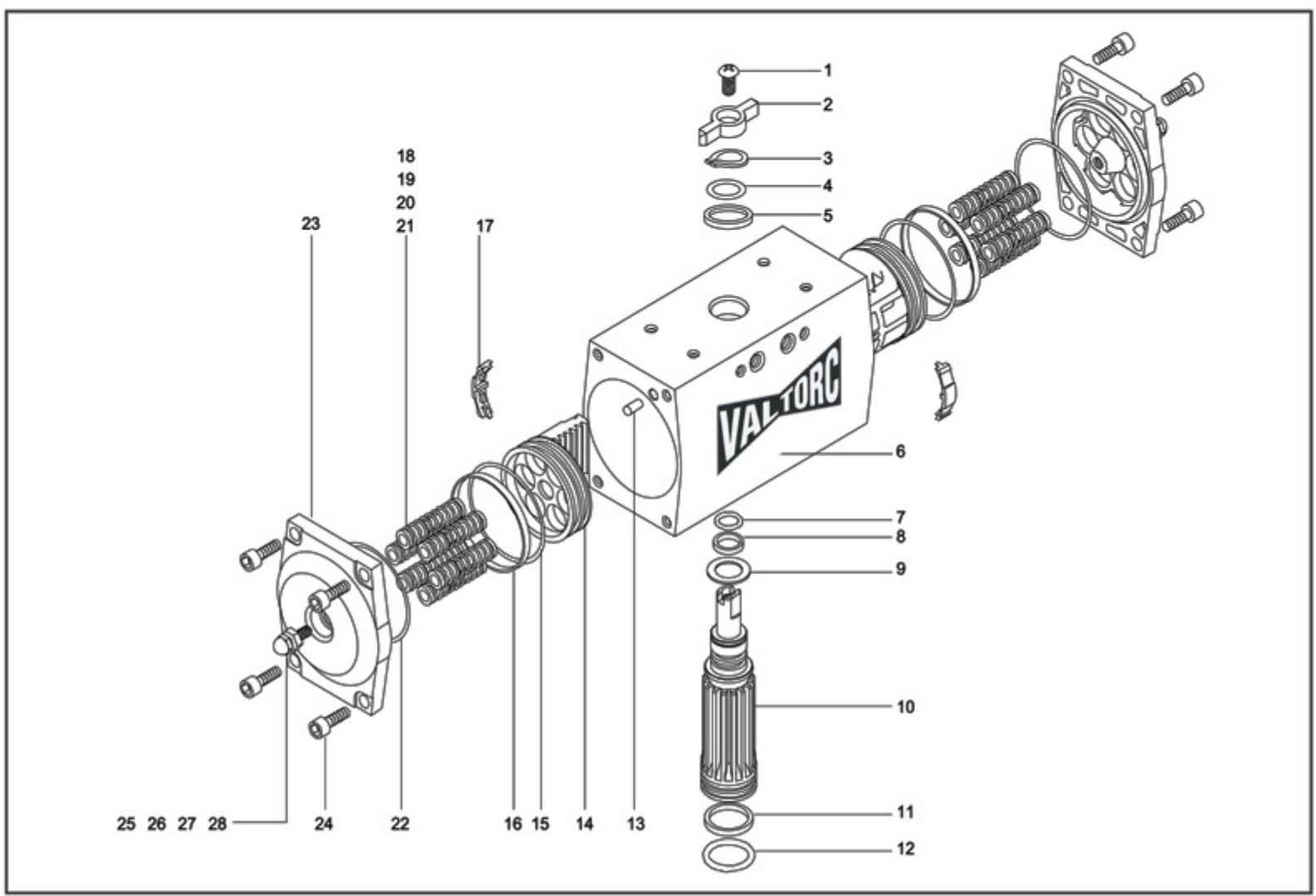

No.	Description	Qty.	Standard Material	No.	Description	Qty.	Standard Material
1	Indicator Screw	1	WCB	15	Piston O-Ring	2	Viton/NBR
2	Indicator	1	Plastic	16	Piston Bearing	2	Plastic
3	Snap Ring	1	Stainless Steel	17	Guide Piston	2	Nylon 66
4	Washer	1	Stainless Steel	18	Spring	*	Steel
5	Outside Washer	1	Plastic	19	Spring Retainer(L)	*	Nylon 66
6	Body	1	Aluminum Alloy	20	Spring Retainer®	*	Nylon 66
7	O-Ring Top	1	Viton/NBR	21	Retainer Connector	*	Brass
8	Bearing Top	1	Plastic	22	End O-Cap Ring	2	Viton/NBR
9	Inside Washer	1	Plastic	23	End O-Cap	2	Aluminum Alloy
10	Pinion	1	Alloy Steel	24	End Cap Stop Screw	8	Stainless Steel
11	Bearing Bottom	1	Plastic	25	Adjust Screw	2	Stainless Steel
12	O-Ring Bottom	1	Viton/NBR	26	Adjust Screw Nut	2	Stainless Steel
13	Plug	2	NBR	27	Adjust Screw Washer	2	Stainless Steel
14	Piston	2	Cast Aluminum Steel	28	Adjust Screw O-Ring	2	Viton/NBR

SERIES DIMENSIONAL DATA (inches)

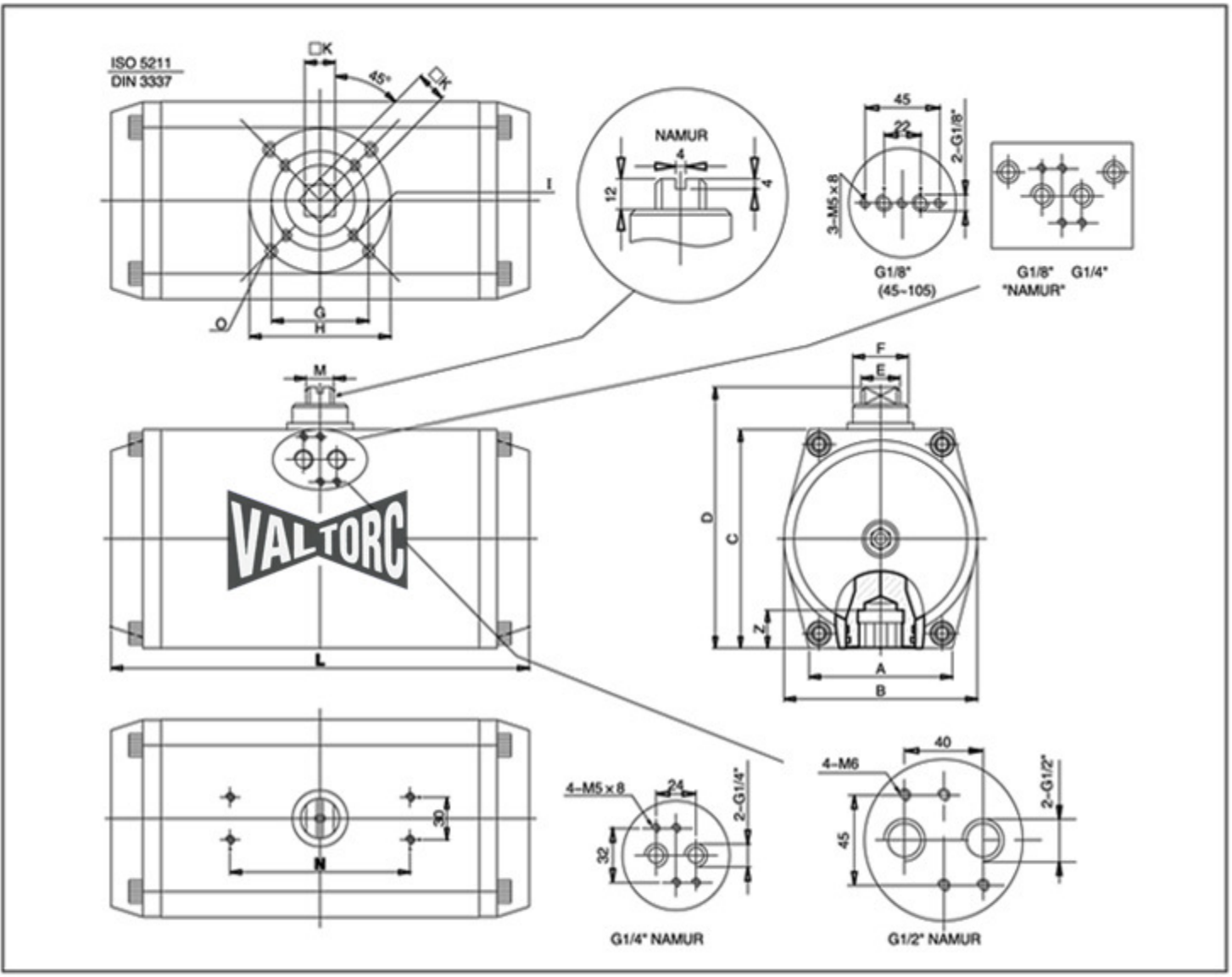

Model	A	B	C	D	E	F	G	H	I	K	L	M	N	O	Z	AIR CONNECTION
45	1.89	2.28	2.56	3.74	0.47	0.55	1.42	1.97	M5x8	0.43	5.75	0.39	3.15	M6X10	0.55	G 1/8"
52	1.97	2.32	2.91	4.09	0.47	0.55	1.42	1.97	M5x8	0.43	5.75	0.39	3.15	M6X10	0.55	G 1/8"
63	2.36	2.83	3.46	4.65	0.47	0.71	1.97	2.76	M6X10	0.55	6.61	0.39	3.15	M8X13	0.71	G 1/8"
75	2.56	3.27	3.94	5.12	0.47	0.71	1.97	2.76	M6X10	0.55	7.24	0.39	3.15	M8X13	0.71	G 1/8"
83	2.64	3.54	4.29	5.47	0.55	0.71	1.97	2.76	M6X10	0.67	8.03	0.39	3.15	M8X13	0.83	G 1/8"
92	2.99	4.09	4.72	5.91	0.71	0.98	1.97	2.76	M6X10	0.67	10.24	0.55	3.15	M8X13	0.83	G 1/8"
105	3.54	4.53	5.24	6.42	0.79	0.98	2.76	4.02	M8X13	0.87	10.55	0.55	3.15	M10X16	1.02	G 1/8"
125	4.09	5.51	6.10	7.28	1.10	1.57	2.76	4.02	M8X13	0.87	11.73	0.79	5.12	M10X16	1.02	NAMUR G 1/4"
140	4.21	5.98	6.75	7.93	1.10	1.57	4.02	4.92	M10X16	1.06	15.35	0.79	5.12	M12X20	1.22	NAMUR G 1/4"
160	5.04	6.92	7.76	8.94	1.42	1.57	4.02	4.92	M10X16	1.06	18.03	1.10	5.12	M12X20	1.22	NAMUR G 1/4"
190	5.31	8.11	9.06	10.24	1.77	2.36		5.51		1.42	20.67	1.26	5.12	M16X25	1.97	NAMUR G 1/4"
210	5.31	8.90	10.04	11.22	1.77	2.36		5.51		1.42	20.94	1.26	5.12	M16X25	1.97	NAMUR G 1/4"
240	6.10	10.08	11.42	12.60	1.77	2.36		6.50		1.81	23.70	1.26	5.12	M20X25	2.36	NAMUR G 1/4"
270	7.48	11.57	12.60	13.78	1.77	2.36		6.50		1.81	28.43	1.26	5.12	M20X25	2.36	NAMUR G 1/2"
300	7.72	12.76	13.70	14.88	1.77	2.36		6.50		1.81	29.21	1.26	5.12	M20X25	2.36	NAMUR G 1/2"
350	8.66	14.96	15.83	17.01	1.77	2.36		6.50		1.81	33.86	1.26	5.12	M20X25	2.36	NAMUR G 1/2"

ACTUATOR OUTPUT TORQUE CHARTS

AIR CONSUMPTION (cubic in.)

Model Number	Opening	Closing	Model Number	Opening	Closing
DA-32	2.4	2.4	DA-160	223	307
DA-45	4.9	6.7	DA-190	360	482
DA-52	6.7	8.5	DA-210	452	591
DA-63	12.2	14	DA-240	652	873
DA-75	18	23	DA-270	1031	1373
DA-83	25	34	DA-300	1452	1812
DA-92	38	56	DA-350	2142	2825
DA-105	57	72	DA-400	3030	2196
DA-125	90	113	DA-500	8092	6713
DA-140	148	195	DA-600	15408	12815

WEIGHT TABLE (lbs)

Model Number	DA	SR	Model Number	DA	SR
32	1.7	N/A	160	44.2	52.4
45	2.3	2.5	190	83.8	98.6
52	2.4	2.7	210	99.2	118
63	4	4.3	240	139	169
75	4.8	5.3	270	206	253
83	6.3	6.9	300	242	286
92	9.5	11.1	350	410	516
105	13.5	15.3	400	636	793
125	19.4	20.4	500	2160	2447
140	26.7	33.7	600	4354	4695



DOUBLE ACTING ACTUATOR OUTPUT TORQUE

Model Number	Input Air Pressure (psi)					
	Output Torque (in/lb)					
	44	58	73	87	102	116
DA-32	40	53	66	80	93	106
DA-45	80	106	133	159	186	212
DA-52	106	142	178	213	250	285
DA-63	189	251	314	377	440	503
DA-75	266	356	445	534	623	712
DA-83	404	538	673	807	942	1076
DA-92	603	804	1005	1205	1407	1608
DA-105	869	1159	1449	1739	2027	2319
DA-125	1354	1814	2266	2717	3168	3629
DA-140	2319	3098	3867	4646	5416	6195
DA-160	3540	4726	5903	7089	8266	9452
DA-190	5416	7222	9027	10832	12638	14443
DA-210	6611	8815	11018	13222	15426	17629
DA-240	9717	12956	16196	19435	22674	25913
DA-270	14762	19682	24603	29524	34444	39365
DA-300	16868	22506	28116	33745	39365	45011
DA-350	30320	40436	50534	60640	70747	80871
DA-400	43206	57614	72012	86420	100819	115227
DA-500	112545	150061	187576	225091	262606	300121
DA-600	216073	288103	360124	432154	504176	576206

Note: The above actuator output torque data has factored in the loss due to friction and passing of the force. The actual output torque of the actuator will be no less than the above data.



SPRING RETURN OUTPUT TORQUE

Model	Springs Per Piston	Input Air Pressure (psi)								Spring Output Torque (in/lb)	
		Actuator Output Torque (in/lb)									
		58		73		87		102		Start 90	End 0
		Start 0	End 90	Start 0	End 90	Start 0	End 90	Start 0	End 90		
SR-45	3	70	52	96	79					51	35
	4	58	34	84	60	111	87	137	113	68	46
	5	45	15	72	42	98	68	125	95	86	58
	6			60	24	87	50	113	77	103	69
SR-52	3	95	73	131	109					69	47
	4	79	50	115	86	150	121	187	158	92	63
	5	63	27	99	63	135	98	171	135	115	79
	6			83	40	119	75	155	112	138	95
SR-63	3	168	129	231	192					117	79
	4	141	89	204	151	266	214	329	277	156	105
	5	112	47	175	110	238	173	301	235	195	132
	6			148	69	211	132	273	195	234	158
SR-75	3	238	195	327	284					161	118
	4	199	141	289	230	377	319	466	408	215	157
	5	159	87	249	176	337	265	427	354	269	196
	6			210	122	298	211	388	300	323	235
SR-83	3	358	278	492	412					247	171
	4	297	191	432	326	566	460	701	595	329	228
	5	237	104	372	239	506	373	641	508	412	286
	6			312	152	446	287	581	421	494	342
SR-92	3	543	419	84	621					384	260
	4	456	292	658	494	858	694	1059	896	512	348
	5	369	164	571	366	771	566	973	767	640	435
	6			484	237	684	437	886	639	768	521
SR-105	3	775	581	1065	870					550	365
	4	647	388	936	677	1227	967	1514	1255	733	486
	5	519	195	808	484	1098	774	1386	1062	916	608
	6			681	291	971	581	1258	869	1099	729
SR-125	3	1212	920	1664	1372					841	566
	4	1009	620	1460	1071	1912	1522	2363	1974	1133	761
	5	805	319	1257	770	1708	1221	2159	1673	1416	956
	6			1062	478	1513	929	1965	1381	1690	1142
SR-140	3	2124	1637	2894	2407					1381	920
	4	1797	1151	2567	1920	3345	2699	4115	3469	1850	1230
	5	1469	664	2239	1434	3018	2213	3788	2982	2310	1540
	6			1920	947	2699	1726	3469	2496	2770	1850
SR-160	3	3204	2434	4381	3611					2177	1443
	4	2690	1664	3867	2841	5053	4027	6230	5204	2903	1929
	5	2177	894	3354	2071	4540	3257	5717	4434	3637	2416
	6			2850	1310	4036	2496	5213	3673	4363	2894



SPRING RETURN OUTPUT TORQUE

Model	Springs Per Piston	Input Air Pressure (psi)								Spring Output Torque (in/lb)	
		Actuator Output Torque (in/lb)									
		58		73		87		102		Start 90	End 0
		Start 0	End 90	Start 0	End 90	Start 0	End 90	Start 0	End 90		
SR-190	3	4991	3770	6797	5576					3452	2230
	4	4248	2620	6053	4425	7859	6230	9664	8036	4602	2974
	5	3496	1460	5301	3266	7107	5071	8912	6876	5761	3726
	6			4558	2115	6373	3921	8169	5726	6912	4469
SR-210	3	5761	4416	7965	6620					3965	2744
	4	4744	2947	6947	5151	9151	7354	11355	9558	5283	3664
	5	3717	1478	5921	3862	8124	5885	10328	8089	6602	4584
	6			4903	2221	7107	4425	9310	6629	7930	5496
SR-240	3	8523	6974	11762	10213	15001	13452			5390	3983
	4	7045	4974	10284	8213	13523	11452	16762	14691	7186	5310
	5	5567	2974	8806	6213	12045	9452	15284	12691	8983	6646
	6			7328	4221	10567	7461	13806	10700	10779	7974
SR-270	3	13434	10894	18355	15815					7903	5620
	4	11355	7965	16275	12886	21196	17806	26116	22727	10540	7487
	5	9266	5036	14187	9956	19107	14877	24028	19797	13178	9372
	6			12107	7027	17027	11948	21948	16868	15815	11240
SR-300	3	14718	11992	20328	17603					9461	7009
	4	12125	8487	17735	14098	23364	19727	28984	25346	12611	9337
	5	9523	4991	15134	10602	20762	16231	26382	21851	15762	11682
	6			12540	7098	18169	12726	23789	18346	18912	14018
SR-350	3	26594	20320	36692	30417					18098	12452
	4	21983	13620	32081	23718	42188	33825	52295	43931	24134	16603
	5	17364	6921	27462	17019	37568	27125	47675	37232	30161	20762
	6			22851	10310	32957	20417	43064	30524	36197	24913
SR-400	3	38312	31497	52711	45896					23497	17364
	4	31878	22789	46277	37188	60684	51596	75083	65994	31338	23160
	5	25444	14080	39483	28479	54251	42887	68649	57286	39179	28948
	6			33409	19780	47817	34188	62216	48587	47002	34736
SR-500	3	106864	79739	144379	117254					63286	38869
	4	92465	56295	129980	93810	167495	131325	205010	168840	84385	51834
	5	78057	32851	115572	70366	153087	107882	190602	145397	105483	64800
	6			101173	46932	138688	84447	176204	121962	126573	77756
SR-600	2	216276	163203							112395	64640
	3	180363	100757	252384	172779	324414	244809			168610	96961
	4			216471	110324	288501	182354	360522	254376	224817	129281

1 - "Spring Output Torque" is under "Loss of Air Pressure" & "Actuator Output Torque" is under spring force condition

2 - Normally Closed Valve: Actuator at 0 degrees, valve is closed; actuator at 90 degrees, valve is open.

3 - Normally Open Valve: Actuator at 0 degrees, valve is open; actuator at 90 degrees, valve is closed.

Note: The above actuator output torque data has factored in the loss due to friction and passing of the force. The actual output torque of the actuator will be no less than the above data.