

VALTORC

WWW.VALTORC.COM
AJBENTAL@VALTORC.COM
1 (866) VALTORC

QUARTER TURN ELECTRIC ACTUATOR



The VALTORC Electric Actuator is designed and engineered for robust, reliable and high performance duty on quarter turn valves. The unique reliable motor module, adjustable cam plate limit switch, self locking mechanism, precision gearing system and ball bearing, auto declutchable mechanism, light rim pull on the hand-wheel, adaptor drive bushing and bottom ISO 5211 mounting dimension are added advantages against others in the field of valve automation. CE approved. FM & UL pending.

Features

- ▶ **Enclosure**
Standard enclosure to water proof and water tight to IP 67, NEMA 4 & 6. Explosion proof Ex d IIBT4 is also available.
- ▶ **Motor**
Squirrel cage motor is of encapsulated type, high stall torque and low inherent force for seating and unseating of valves. All motors are integrated with build-in thermal protection.
- ▶ **Internal Components Arrangement**
Internal mechanical and electrical components are designed in modular mounting arrangement, and can be easily removed for maintenance purpose. Optional accessories are also available.
- ▶ **Limit Switches**
A pair of limit switches are activated by means of simple, reliable and adjustable cam plates, mounted directly on, and driven by center column. The unique cam plate design does not allow over travel of limit switches. Two auxiliary limit switches are standard.
- ▶ **Torque Switches**
Electric Actuator with 885 In-Lbs and above, are installed with torque switches for over load protection.
- ▶ **Heater**
A 20 or 5 watt space heater is provided inside all the VALTORC Electric Actuators for prevention of condensation due to weather and temperature changes, as well as to keep internal components clean and dry.
- ▶ **Self Locking Mechanism**
All Electric Actuators have a self locking worm gear design to keep position of valve unchanged against reverse torque of valve.
- ▶ **Handwheel**
Hand-wheel on the Electric Actuator ensures adequate strength for safe and efficient emergency operation.
- ▶ **Manual Override**
The manual override is engaged by pulling the lever and turning the hand-wheel. Lever declutches automatically when power supply is switched on, and hand-wheel does not turn as extra safety feature.
- ▶ **Visual Position Indicator**
The visual position indicator is directly mounted on the center drive column to show the visual position of the valve.
- ▶ **Stop Adjustment**
One each for open and close position (adjustable). Provides for +/- 5 degrees adjustment.
- ▶ **Mounting & Adaptation**
Bottom flange mounting dimensions conform to ISO 5211. An adaptor drive bushing is provided for every electric actuator to provide direct mounting to all VALTORC Actuators.

Application

The VALTORC Electric Actuator is designed and engineered for robust, reliable and high performance duty on quarter turn valves. The unique reliable motor module, adjustable cam plate limit switch, self locking mechanism, precision gearing system and ball bearing, auto declutchable mechanism, light rim pull on the hand-wheel, adaptor drive bushing and bottom ISO 5211 mounting dimension are added advantages against others in the field of valve automation. CE approved. FM & UL pending.

Technical Information

Model		EL520	EL885	EL2124	EL4425	EL7080	EL26550
Rated torque (Lbs-Inch)		520	885	2,124	4,425	7,080	26,550
Rated torque (Nm)		60	100	240	500	800	3000
Operating time (second)	50Hz	17	21	26	31	39	59
	60Hz	14	18	22	26	32	50
Actuator bushing	Double D	0.55 x 0.39 / 0.63 x 0.43	0.75 x 0.51	0.87 x 0.63	1.18 x 0.87	-	-
Connection Sizes (Inch)	Round & Keyed	-	-	-	1.38 / 0.39x0.39	1.38 / 0.39x0.39	1.97 / 0.39x0.47
Actuator bushing	Double D	14 x 10 / 16 x 11	19 x 13	22 x 16	30 x 22	-	-
Connection Sizes (mm)	Round & Keyed	-	-	-	35 / 10x10	35 / 10x10	50 / 10 x 12
Rated current (A)	1Phase / 110V / 50HZ	1.25	0.98	1.62	3.6	3.9	-
	1Phase / 110V / 60HZ	1.25	1.1	1.72	3.9	4.2	-
	1Phase / 220V / 50HZ	0.4	0.52	0.87	1.5	2.05	3.75
	1Phase / 220V / 60HZ	0.4	0.58	0.9	1.6	2.2	3.85
	3Phase / 380V / 50HZ	N/A	0.43	0.32	0.52	0.82	1.6
	3Phase / 380V / 60HZ	N/A	0.33	0.32	0.56	0.88	2
	3Phase / 440V / 50HZ	N/A	0.59	0.32	0.55	0.82	2.5
	3Phase / 440V / 50HZ	N/A	0.42	0.35	0.58	0.88	2.4
Motor insulation class		F	F	F	F	F	F
ISO 5211 mounting flange		F07	F07	F07/F10	F10/F12	F12/F14	F16
Weight (Lbs)		19	15	33	44	55	93
Weight (Kgs)		9	7	15	20	25	42
No of handwheel turns		8.5	10	12	14	17	13

* Contact Factory for Delivery

Basic Actuator Dimensions (inch)

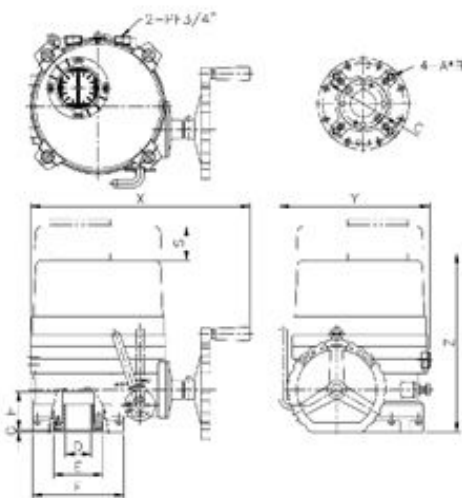

Type	EL520	EL885	EL2124	EL4425	EL7080	EL26550
Flange	F07	F07	F07	F10	F12	F16
ISO5211			F10	F12	F14	
C (∅)	2.756	2.756	2.756 / 4.016	4.016 / 4.921	4.921 / 5.512	6.496
A	M8	M8	M8/M10	M10/M12	M12/M16	M20
B	0.551	0.551	0.551 / 0.669	0.669 / 0.826	0.787 / 0.984	1.259
D (Key) ∅	0.866	0.866	0.984	1.575	1.89	2.95
D (Squ.) □		0.787	0.906	1.339	1.575	2.52
E (∅)	2.165	1.969	2.303	3.15	3.74	5.315
F (∅)	4.01	3.465	4.921	5.827	7.008	8.89
G	0.196	0.118	0.118	0.118	0.118	0.197
H	1.377	1.457	2.244	2.441	2.638	3.543
S		3.937	4.528	5.709	6.693	8.85
X	9.488	10.157	13.307	14.055	14.961	17.32
Y	8.188	6.772	9.016	9.606	11.299	14.76
Z	10.078	8.661	10.197	11.339	12.323	15.15

Standard Specifications

- Enclosure ▶ Weatherproof IP67, NEMA 4 and 6, O-ring sealed
- Main Power supply ▶ 110/220 VAC - 1Ph/50/60Hz
▶ 380/440 VAC - 3Ph/50/60Hz
- Control power supply ▶ 110/220 VAC - 1Ph/50/60Hz
- Duty cycle(on-off) ▶ S2: 10Min~30Min / S4: 20~50%
- Packing ▶ Graphite
- Drive Pin ▶ 17-4- PH SS ASTM A564 - TYPE 630
- Duty cycle(modulating) ▶ S4, 30~50%, 300~1200 start/Hour
- Motor ▶ Squirrel Caged induction motor
- Torque switches ▶ 1 each for Open and Close (SPDT 250VAC/10A rating) Except for 2E 005
- Stall protection/ set temp. ▶ Built in Thermal protection
- Travel angle ▶ 90 ° +/- 5 °
- Position indicator ▶ Continuous Position Indicator with arrow
- Manual override ▶ De-clutchable
- Self locking ▶ Provided by double worm gearing (no brake)
- Mechanical stop ▶ 1 each for each travel end (Open and Close), external & adjustable
- Space Heater (for anticondensation) ▶ 20W (110/220 VAC) For RL520
▶ 5W (110/220 VAC) For EL885 and above
- Conduit entries ▶ (2) 3/4" NPT
- Lubrication ▶ EP type grease
- Ambient temperature ▶ Basic actuator : -40F~+158oF
c/w control options : 140F~+140oF
- Ambient humidity Anti ▶ 90%RH Max (Non-Condensing)
- vibration ▶ XYZ 10g. 02~34Hz, 30 minutes
- External coating ▶ Dry powder (Polyester)

How to Order

Series	Size	Motor and Power Supply			Actuator Bushings	Special Options
Series	Size	No of Phases	Volts	Hz	Insert Size	Special Options
EL = Quarter Turn Electric Actuator	520 = 520 In-Lbs	1 = 1 Phase	1 = 110V	1 = 50 Hz	*** Please see "Bushings Codes" page for available inserts.	00= No special requirements
	885 = 885 In-Lbs	3 = 3 Phases	2 = 220V	2 = 60 Hz		MC = Modulating Control Card
	2124 = 2,124 In-Lbs		3 = 380V			BB = Battery Back up
	4425 = 4,425 In-Lbs		4 = 440V			
	7080 = 7,080 In-Lbs					
	26550 = 26,550 In-Lbs					

VALTORC				
Bushing Code	Dimensions (in.)	Dimensions (mm)	Applicable Actuator Size	Matching Valve Size
XXX	no insert	no insert	no insert	—
01D	0.551 x 0.394	14 x 10	EL250	2", 2.5", 3"
02D	0.630 x 0.433	16 x 11	EL520	4"
03D	0.748 x 0.512	19 x 13	EL885	5", 6"
04D	0.866 x 0.630	22 x 16	EL2124	8"
05D	1.181 x 0.866	30 x 22	EL4425	10" & 12"
22R	1.38 dia. (round & keyed)	35	EL4425, 7080	14" & 16"
23R	1.97 dia. (round & keyed)	50	EL26550	18" & 20"
24R	2.50 dia. (round & keyed)	64	EL26550	24"

VALTORC INTERNATIONAL
P.O. BOX 1928
KENNESAW, GA 30156

AJBENTAL@VALTORC.COM
WWW.VALTORC.COM
1-866-VALTROC

